

# Infinitival *to*\*

Yehuda N. Falk

Department of English

The Hebrew University of Jerusalem

msyfalk@mssc.huji.ac.il

<http://pluto.mssc.huji.ac.il/~msyfalk/>

In the welcome rush to study linguistic universals, narrow parochial questions of the syntax of English tend to get ignored. This paper is a study of a narrow parochial question of the syntax of English: the categorization of the infinitive marker *to*. Naturally, the resolution of questions of this nature will also have consequences for a theory of Universal Grammar.

For the most part, we will try to remain as theory-neutral as possible. This means that theory-internal arguments will not be invoked. However, the conclusion that we reach will have clear theoretical implications. We also must assume some theory of categories. We will assume a fairly conventional  $\bar{X}$  theoretic view of categories (Chomsky 1986; Bresnan to appear). In the verbal/clausal system, we assume the existence of three categories: V(erb), I(nfl), and C(omplementizer). The category V is the lexical core of a clausal constituent. The category I carries tense, aspectual, and agreement features: in English, modal auxiliaries belong to this category and (in surface constituent structure) tensed forms of *be* and auxiliary *have* occupy the I position as well. In other languages, all tensed verb forms may be in I, or I may always be a (morphosyntactically) free form with no verbal elements.<sup>1</sup> The category C is the familiar category of complementizers. In English, the specifier position of IP is the (surface) position of subjects and the specifier position of CP is the (surface) position of *wh* operators. We take this to be a fairly middle-of-the-road position: unlike some lexicalist researchers, we accept the category Infl, but unlike much research in the GB/Minimalist tradition, we do not recognize other functional categories (AGR, ASP, TRANS, etc.) which are not lexically justifiable.

There seem to be three basic views in the theoretical literature concerning the categorization of *to*: C (Postal and Pullum 1978, Falk 1984a, Sag and Wasow 1999), I (Chomsky 1981, Koster and May 1982), and V (Pullum 1982, Pollard and Sag 1994).<sup>2</sup> Couched in this superficial disagreement is the consensus that *to* is a head within the clausal system: it heads either a CP, an IP, or a VP.

---

\*This paper was inspired by Pullum (1982). I hereby acknowledge this debt. This paper has benefitted from comments on earlier drafts by Joan Bresnan, Edit Doron, Tsipi Kuper-Blau, Anita Mittwoch, and Yael Ziv.

As in Pullum (1982), the sample sentences in this paper are inhabited by characters from **STAR TREK**. I would like to thank the producers of the various **STAR TREK** series, and the late Gene Roddenberry, for creating such a “fascinating” universe.

<sup>1</sup>Whether Infl can include sublexical features is a theory-internal question: in derivational theories it generally does, while in theories that have some version of the lexical integrity principle (such as LFG) it does not.

<sup>2</sup>In addition, Mittwoch (1990) argues that *to* is a modal auxiliary, without committing to a specific category identity.

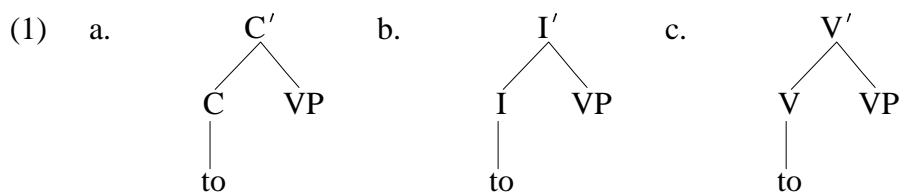

We assume the head status of *to* in what follows. (For discussion and rejection of other possibilities, see Pullum 1982.)

The position to be argued for here is that *to* is a member of category C. The argument will be somewhat indirect. We will first show that the *to* infinitive must be a CP. This constitutes an indirect argument for the C-hood of *to*, because it seems to head a CP. However, the CP-hood of a *to* infinitive does not necessarily mean that *to* is C, because infinitives could also be analyzed with *to* as I or V with a null complementizer heading the CP. We will then proceed to show that arguments purporting to show that *to* is an I or V are faulty.

## 1. Infinitives as CP

Infinitives must be CPs because they have the same distribution as CPs. In environments where it is possible to distinguish between CP, IP,<sup>3</sup> and VP distribution, it is clear that infinitives pattern with CPs.<sup>4</sup> For example, CPs can be subjects; IPs and VPs cannot. Infinitives can also be subjects.<sup>5</sup>

- (2) a. That Kirk defeated a Gorn surprised me.  
 b. \*Kirk defeated a Gorn surprised me.  
 c. \*Defeat a Gorn surprised / would surprise me.  
 d. To defeat a Gorn would surprise me.

The CP status of infinitives also emerges from a consideration of complements to various categories. For example, CPs and infinitives can serve as arguments to nouns, while IPs and VPs cannot.

- (3) a. Picard's intention that the Enterprise would fight the Borg  
 b. \*Picard's intention the Enterprise would fight the Borg

---

<sup>3</sup>I am assuming here that finite clauses with no overt evidence of a complementizer or material in [SPEC, CP] are bare IPs, rather than CPs with null complementizers. In a theory in which this is impossible, IPs have no distribution other than as complement of C. I am also assuming that the analysis of Raising-to-Subject infinitives and ECM/Raising-to-Object infinitives as bare IPs is not a given. It seems to me that this is a position that needs to be argued for rather than stipulated for theory-internal reasons. If the conclusion to be reached here that *to* is not an I is correct, this analysis of Raising infinitives must be wrong.

<sup>4</sup>Many of the distributional properties would also be consistent with the *to* infinitival being a PP, which is its historical source. For arguments against a PP analysis, see Pullum (1982).

<sup>5</sup>This argument is mentioned by Pollard and Sag (1994). However, since they accept Pullum's (1982) analysis of *to* as a verb, they analyze infinitives of this kind as having an empty complementizer. The structure (replacing their VP[*comp*] with CP) is:

- (i) [<sub>CP</sub> e [<sub>VP</sub> to defeat a Gorn]]

- c. \*Picard's intention fight(ing) the Borg
- d. Picard's intention to fight the Borg

VPs cannot serve as complements to adjectives; CPs, IPs, and infinitives can.

- (4) a. proud that he serves in Starfleet
- b. proud he serves in Starfleet
- c. \*proud serve/serving in Starfleet
- d. proud to serve in Starfleet

On the other hand, clausal complements to prepositions can only be IP; CP, VP, and infinitives are all ungrammatical.

- (5) a. \*before that she served in Starfleet
- b. before she served in Starfleet
- c. \*before serve in Starfleet
- d. \*before to serve in Starfleet

Another distributional argument for the CP status of *to* infinitivals is the fact that they can be introduced by *wh* operators.

- (6) a. Janeway asked how to protect the Ocampo.
- b. Odo didn't know who to charge with the crime.

On the generally accepted view that the structural position occupied by *wh* operators is the specifier position of CP, this is further evidence that infinitival clauses are CP.

As noted earlier, the demonstration that infinitives are CP is not sufficient to argue that *to* is C. It is possible that infinitival CPs have an empty C with an IP or VP complement. That is to say, the possible structures for infinitives are now as follows (with a neutral position on the structural presence of the unexpressed subject).

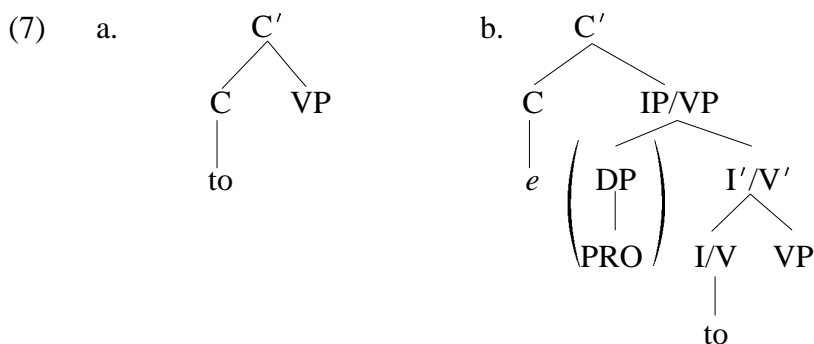

However, we assume that the simpler structure in (7a) is a priori the preferable one. That is to say, the burden of proof is on the proponent of the more complex structure in (7b) to show that *to* is an I or V.

## 2. NonArguments for I- or V-hood

In this section we show that arguments that have been raised in the past that *to* is I or V are invalid.

### 2.1. VP Ellipsis

VP Ellipsis has been used as an argument both for the analysis of *to* as I (Koster and May 1982) and for the analysis as V (Pullum 1982). Apparently, the argument is that English has a rule of the form:

- (8) In the configurations [I VP] and [V VP], the VP can be optionally ellipped/omitted/deleted. The I/V is stranded.

This rule accounts for the grammaticality of the following cases of VP Ellipsis.

- (9) a. Uhura can<sub>I</sub> [~~fix the transmitter~~].  
 b. In a fit of anger, Q did<sub>I</sub> [~~send the Enterprise into Borg space~~].  
 c. Zephram Cochrane might have<sub>V</sub> [~~settled in the Alpha Centauri system~~].  
 d. Trelane stopped<sub>V</sub> [~~chasing Kirk~~].

The requirement that an I or V be stranded is supposed to account for the ungrammaticality of the following.

- (10) a. \*In a fit of anger, Q [~~sent the Enterprise into Borg space~~].  
 b. \*On its maiden voyage, Kirk [~~saved the Enterprise-B~~].

Given this analysis of ellipsis, there is a contrast between the ability of uncontroversial complementizers and *to* to be stranded by ellipsis.

- (11) a. \*McCoy thinks that [~~Spock is too unemotional~~].  
 b. \*The Horta attacked as soon as [~~her eggs were stolen~~].  
 c. \*Guinan asked if [~~anything was wrong~~].

- (12) \*Kira hoped for [~~Bareil to be elected Kai~~].

- (13) a. Data wants to [~~be human~~].  
 b. Odo expects Quark to [~~smuggle contraband onto the station~~].

Since complementizers cannot be stranded, so the argument goes, the fact that *to* can be stranded shows that it is not a complementizer.

This argument suffers from a fatal flaw. The only category in English that freely ellipses is VP. In the sentences in (11) (and, under some assumptions, (12)), what is ellipsed is IP, not VP. Therefore, there is no reason to expect these ellipses to be grammatical. There is no reason on the basis of these data to consider *to* a V or I.

If *to* is a complementizer, the rule of VP Ellipsis would have to be slightly restated.

- (14) In the configuration [C/I/V VP], the VP can be optionally ellipsed/omitted/deleted. The head is stranded.

On the assumption that the categories C, I, and V form a natural class, this may well be a simpler rule than one that specifies only I and V. We leave open the question of whether this rule needs to be stated in terms of what can be stranded, which seems dubious in any case. The point is that even if it does, VP Ellipsis does not provide an argument that *to* is not a complementizer.

## 2.2. Bare VP complements

Another argument that *to* is either V or I is provided by Pullum (1982) and Mittwoch (1990). They observe that the complement of *to* is a bare VP with an uninflected verbal head. Bare uninflected VP complements are also attested in cases such as the following.

- (15) a. Trelane *made* Spock [recite a poem].  
 b. The wormhole *lets* people [travel to the Gamma Quadrant].  
 c. The Federation *helps* the Bajorans [rebuild their planet].
- (16) a. The Romulans *might* [attack Vulcan].  
 b. The Borg *will* [assimilate everyone].  
 c. Uhura *can* [open hailing frequencies].

In the theory of categories that Pullum assumes, the italicized heads in both (15) and (16) are verbs. Thus, Pullum concludes that only verbs can take bare VP complements, and *to* must therefore be a verb. In the categorization assumed by Mittwoch, the heads in (15) are verbs and those in (16) are modals. Mittwoch's conclusion is that *to* is a modal. We categorize modals as Infl (Falk 1984b).

The basic generalization is that V and I can take bare VP complements; C, as the other verbal category, should be expected to have this capability as well. None of the uncontroversial complementizers can take bare VP complements. If our proposal is correct, *to* fills this otherwise open gap. The bare VP complement thus provides no evidence for categorizing *to* as V (or I), and can in fact be used as a suggestive argument for categorizing it as C.

## 2.3. Need for a structural subject position

Koster and May (1982) argue that, since infinitival clauses demonstrably have syntactic (although unexpressed) subjects, they must have a structural subject position. Under current versions of  $\bar{X}$  theory, such a position would be either [SPEC, IP] or [SPEC, VP]. Plausibly, then, *to* is either I or V.

This argument rests on the assumption that subjects must be represented in a structurally uniform manner. This is not uncontroversial. In theoretical frameworks like LFG and HPSG, for example, subjects need not be represented structurally at all. Even within the GB framework other structural positions are available for subjects, such as small-clause subject or [SPEC, VP] in the complement of *to*. This is therefore not an empirical argument, but a theoretical claim to be confirmed empirically.

## 2.4. Finiteness features

Koster and May (1982) observe that *to* carries a feature [-finite]. Since the feature [ $\pm$ finite] is associated with the category I, it follows that *to* must be a I. As with the previous argument, this is a theoretical claim rather than an empirical argument.

The assumption made by Koster and May is in fact only one of three possible alternatives. It is equally possible that only the feature [+finite] is associated with the category I, or that there is no one-to-one correlation between categories and features. Under either of these alternatives, Koster and May's conclusion would not follow.

Ultimately, the correctness of one of the possible views about the relationship between the feature [finite] and the category I is an empirical question. The categorization of *to* is a prerequisite for answering this question.

## 2.5. Entailment of complement

Mittwoch (1990) argues that the states of affairs expressed by bare infinitive complements are entailed by the larger sentence while the states of affairs expressed by *to* infinitives are not.

- (17) a. Kirk saw Edith cross the street. [entails that Edith crossed the street]  
 b. Kirk expected Edith to cross the street. [does not entail that Edith crossed the street]

She attributes this nonentailment to *to*, and suggests that this is a modal-like property.

It is unclear that a syntactic property is involved here at all. But even if the lack of entailment is to be traced back to syntax, it is not clear that it is the presence of a modal that is involved. The same lack of entailment is possible with a complement that has no modal in it.

- (18) Kirk believes that Edith crossed the street. [does not entail that Edith crossed the street]

It is possible that the presence of a complementizer is crucial here. This does not seem to be an argument for categorizing *to* as an Infl.

## 2.6. Adverbials and floated quantifiers

A syntactic distributional argument offered by Mittwoch (1990) is based on the positioning of words like *all* and *really*.

- (19) a. The Klingons can all board the ship.  
 b. Kirk might really enjoy being captain.
- (20) a. The Klingons want to all board the ship.  
 b. Kirk seems to really enjoy being captain.

However, the position of *all* and *really* is based on the following VP, not a preceding modal.

- (21) a. Worf made the Klingons all board the ship.  
 b. Good luck helped Kirk really enjoy being captain.

This has no bearing on the categorization of *to*.

## 2.7. Other arguments

Pullum (1982) provides several additional arguments ostensibly supporting the verb analysis of *to*. We will not deal with them extensively, but we will show briefly that a couple

of them do not distinguish between V and C, although they may provide arguments against the Infl analysis.

One of the points Pullum makes, based on Zwicky and Levin (1980), is that *to* is resistant to stress.<sup>6</sup>

- (22) a. \*I want the Enterprise TO boldly go where no one has gone before.  
b. \*The Yorktown didn't go there, but I expect the Enterprise TO.

Pullum claims that in this way it is like infinitive forms of auxiliaries. This property of *to* contrasts with the behavior of Infs, which can be freely stressed.

- (23) a. The Enterprise WILL boldly go where no one has gone before.  
b. The Yorktown didn't go there, but the Enterprise WILL.

However, complementizers are also resistant to stress.

- (24) \*I think THAT the Enterprise should boldly go where no one has gone before.

Neither *to* nor complementizers are completely unstressable; some complementizers (like conditional *if*) can be stressed,<sup>7</sup> and Mittwoch shows that *to* can receive contrastive stress.

- (25) a. I'll beam aboard the Enterprise IF O'Brien operates the transporter.  
b. I wouldn't be upset not to be chosen for the away team, but on the other hand, I wouldn't be upset TO be chosen either.

But they are both more resistant to stress than Infl. This resistance to stress is actually expected of functional elements, including complementizers and auxiliaries, and it is the free stressability of Infl that is surprising. In any case, while the stress facts can serve as an argument against the Infl analysis of *to*, they cannot be used to argue against the analysis of *to* as complementizer.

Another observation made by Pullum is that *not* can precede *to*.

- (26) Q wants the Enterprise not to boldly go where no one has gone before.

Since *not* follows Infs, this is another argument against the Infl analysis.

- (27) a. \*The Enterprise not will boldly go where no one has gone before.  
b. The Enterprise will not boldly go where no one has gone before.

However, as noted by Hornstein (1977), *not* can also precede constituents of categories other than VP.

---

<sup>6</sup>Zwicky and Levin limit the unstressability of *to* to situations when it is stranded by VP Ellipsis, and Pullum follows them on this. It seems to me, though, that it is (at least relatively) resistant to stress in other contexts as well. By limiting discussion to VP Ellipsis constructions, Pullum automatically excludes consideration of complementizers. The particular resistance to stress before a VP Ellipsis site is interesting and in need of expansion, as Zwicky and Levin point out, but it is not clear to me that it is germane.

<sup>7</sup>I thank Tsipi Kuper-Blau (personal communication) for this observation.

- (28) a. [<sub>DP</sub> Not one starship] was able to defeat the Enterprise.  
 b. Spock seemed [<sub>AP</sub> not very logical] during pon-farr.  
 c. [<sub>CP</sub> Not that it matters], but Picard was assimilated by the Borg.

It is thus not clear that the positioning of *not* before *to* can be used to argue that *to* is a verb.

## 2.8. Conclusion

The arguments that have been made for categorizing *to* as V or I are not very compelling. We conclude, then, that since the infinitival clause is a CP, *to* is a C.

It is striking that the argument for the complementizer status of *to* is indirect. In this respect, we echo the observation made by Pullum (1982: 205) that

[n]one of the above arguments is compelling enough to sway a hardened conservative... An empiricist who believes that syntactic analyses should spring out of the raw facts will not be convinced, for the arguments I have put forward rest on subtle simplifications of the grammar at a fairly abstract level.

However, as Pullum thought was true for his analysis of *to* as a verb, the analysis of *to* as a complementizer argued for here results in a simpler grammar than either of the alternatives.

If the analysis proposed here is correct, it has interesting implications for syntactic theory. It means, for example, that contrary to the assumption in the transformational tradition, the presence of an understood subject cannot be used as evidence for an IP node. It also means that the assumption that the feature [ $\pm$ finite] is associated invariably with the category I is also incorrect. Conversely, since infinitives are CPs, it also means that Brame's (1976) proposal that infinitives constitute a distinct category to account for subcategorization in obligatory equi verbs is also incorrect.

## 3. On *For* Infinitivals

One interesting problem created by our analysis of *to* infinitives is the structure of the bracketed element in (23).

- (29) [For Picard to beam down to the planet] would be dangerous.

It is usually assumed that the structure of the *for* clause is something like:

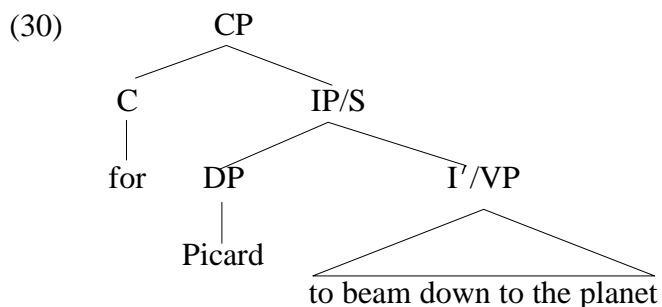

Under this analysis, *for* is a complementizer and the DP after *for* is analyzed as occupying the normal structural position for subjects ([SPEC, IP] or NP-under-S). Our analysis of the *to*-VP construction as a CP renders such an analysis impossible.

While the analysis of *for* as complementizer is traditional in generative work, it is not the only possibility. Jespersen (1940: 308) characterizes *for* as a “mere grammatical sign of the subject (S) of the infinitival nexus,” i.e. as a preposition Case-marking the subject of the infinitive. Such an analysis draws a connection between English and languages that mark the subjects of infinitives dative. We can adopt this idea in phrase structure terms as follows.<sup>8</sup>

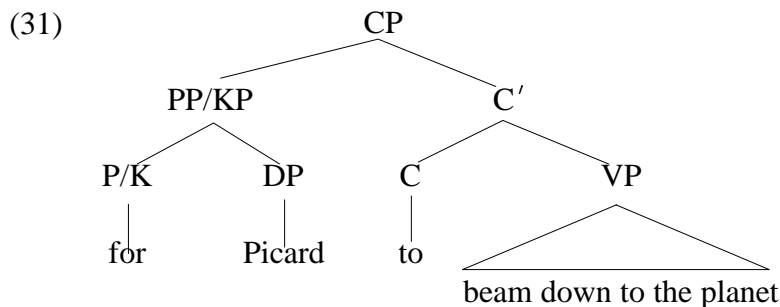

This analysis has the advantage of capturing directly the mutual dependence between *for* and the subject, which is captured indirectly in other analyses. There also seems to be some evidence for treating *for* and the DP as a constituent: *for* + DP can be coordinated, while complementizer–subject strings are not generally coordinatable.

- (32) a. Trelane wishes [[for Kirk and for Spock] to beam down].  
 b. \*Trelane expects [[that Kirk and that Spock] will beam down].

For this to work, subjects would have to be allowed to occupy [SPEC, CP] position. A structure in which *for* and the subject form a constituent was first proposed (as a derived structure) by Emonds (1976). Emonds observes that adverbials cannot be positioned between *for* and the nominal, even though with other complementizers adverbials can occur in that position. He also observes that such an analysis accounts for the accusative marking on the nominal.

A less radical alternative analysis would be as follows:

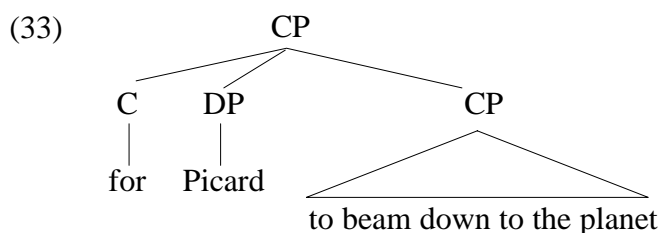

This analysis is basically a “Raising-to-Object” analysis of *for* clauses. The nominal following *for* is the (nonthematic) object of *for*, and is understood as the subject of the complement CP.

---

<sup>8</sup>I would like to thank Joan Bresnan (personal communication) for suggesting an analysis along these lines to me.

Within a theoretical framework that recognizes Raising-to-Object, such as LFG or HPSG, an analysis along these lines should be unproblematic.<sup>9</sup>

One way or another, *for* infinitives do not seem to present an insurmountable problem for the analysis proposed here. What is required is a rethinking of the structure of *for* clauses, and probably a rejection of the analysis of *for* as complementizer.

## 4. Conclusions

We have argued in this paper that *to* infinitivals are CPs, and that *to* is a complementizer. This conclusion has important consequences for general syntactic theory. A theory of syntax has to be based on careful empirical study, not just abstract theoretical principles. For example, the theoretical desire to make finite and nonfinite clauses have the same constituent structure, which motivates much work on infinitives in the GB and Minimalist traditions, has been shown to be empirically inadequate.

The categorization of *to* as a complementizer is not in principle in conflict with any current theory of syntax, although it is in conflict with specific analyses that have been proposed in the contexts of various theories. For this reason, this paper has tried, as much as possible, to be theory-neutral in its argumentation.

An interesting next step would be to examine infinitives in other languages in the light of the arguments presented in this paper. It may turn out that infinitives are I-less CPs generally, or it may turn out that the peculiarities of English, such as the existence of the infinitive particle *to*, produce a structure that is significantly different from those found in other languages. Only careful empirical argumentation will be able to resolve such questions.

## References

- Brame, Michael K. (1976) *Conjectures and Refutations in Syntax and Semantics*. New York: Elsevier North-Holland.
- Bresnan, Joan (in preparation) *Lexical-Functional Syntax*. ms., Stanford University.
- Chomsky, Noam (1981) *Lectures on Government and Binding*. Dordrecht: Foris.
- Chomsky, Noam (1986) *Barriers*. Cambridge, Mass.: MIT Press.
- Emonds, Joseph E. (1976) *A Transformational Approach to English Syntax: Root, Structure Preserving, and Local Transformations*. New York: Academic Press.
- Falk, Yehuda N. (1984a) *Grammatical Configurations and Grammatical Relations*. Doctoral dissertation, MIT
- Falk, Yehuda N. (1984b) "The English Auxiliary System: A Lexical-Functional Analysis." *Language* 60: 483–509.
- Hornstein, Norbert (1977) "S and X' Convention." *Linguistic Analysis* 3: 137–176.
- Jespersen (1940) *A Modern English Grammar on Historical Principles, Part V: Syntax, Fourth Volume*. London: George Allen and Unwin.
- Koster, Jan, and Robert May (1982) "On the Constituency of Infinitives." *Language* 58: 116–143.

---

<sup>9</sup>Within a framework that does not recognize Raising-to-Object, this analysis could perhaps be formalized with a small-clause approach. The subject would be adjoined to the CP headed by *to*. I will not work out the details here.

- Mittwoch, Anita (1990) "On the Distribution of Bare Infinitive Complements in English." *Journal of Linguistics* 26: 103–131.
- Pollard, Carl, and Ivan A. Sag (1994) *Head-driven Phrase Structure Grammar*. Stanford: CSLI Publications.
- Postal, Paul M., and Geoffrey K. Pullum (1978) "Traces and the Description of English Complementizer Contraction." *Linguistic Inquiry* 9: 1–29.
- Pullum, Geoffrey K. (1982) "Syncategorematicity and English Infinitival *to*." *Glossa* 16: 181–215.
- Zwicky, Arnold M., and Nancy S. Levin (1980) "You Don't Have *Tó*." *Linguistic Inquiry* 11: 631–636.